

THE  
**BARRETO**  
MODEL E1320H/E1620B  
HYDRAULIC REAR TINE TILLER  
EXPLODED VIEWS WITH PART NUMBERS

CONGRATULATIONS!

You are now the proud owner of a BARRETO tiller. The following pages have detailed views of your tiller, along with corresponding part numbers. If you have any questions or need any replacement parts in the future, please contact us at your convenience. Our toll-free phone number, fax and email are listed below and parts may be ordered through any of these methods.

Thank you for your patronage and confidence in BARRETO equipment.

Barreto Manufacturing, Inc.  
Innovative Equipment Engineered to Last  
66498 Highway 203  
La Grande, OR 97850  
1-800-525-7348  
1-541-963-6755 Fax  
E-Mail: [info@barretomfg.com](mailto:info@barretomfg.com)  
Web Site: <http://www.barretomfg.com>

Machine Identification Record

BARRETO Customer number \_\_\_\_\_

Machine model number \_\_\_\_\_

Machine serial number \_\_\_\_\_

Engine manufacturer \_\_\_\_\_

Engine model number \_\_\_\_\_

Engine serial number \_\_\_\_\_

REF.	QTY.	PART NO.	DESCRIPTION
1	1	04016	ACTUATOR VALVE, O-RING PORTS
2	1	05028	C-CLIP, 3/4"
3	1	03055	SPRING, VALVE SPOOL RETURN
4	2	03056	COLLAR, 3/8 ID
5	1	05108	WASHER, 3/8 USS, ZINC
6	1	05092	HH CAP SCREW, 3/8-16 NC X 1-1/2 G5 ZINC
7	1	04567	FITTING, 6407-8-8
8	1	03077	O-RING, -8 FITTING
9	1	04008-BO	RELIEF VALVE, 3000 POUND, O-RING
10	1	10481	RETURN TUBE, #8 O-RING

① FOR 1620, USE PART NO. 04008-CO (3500 POUND RELIEF VALVE).

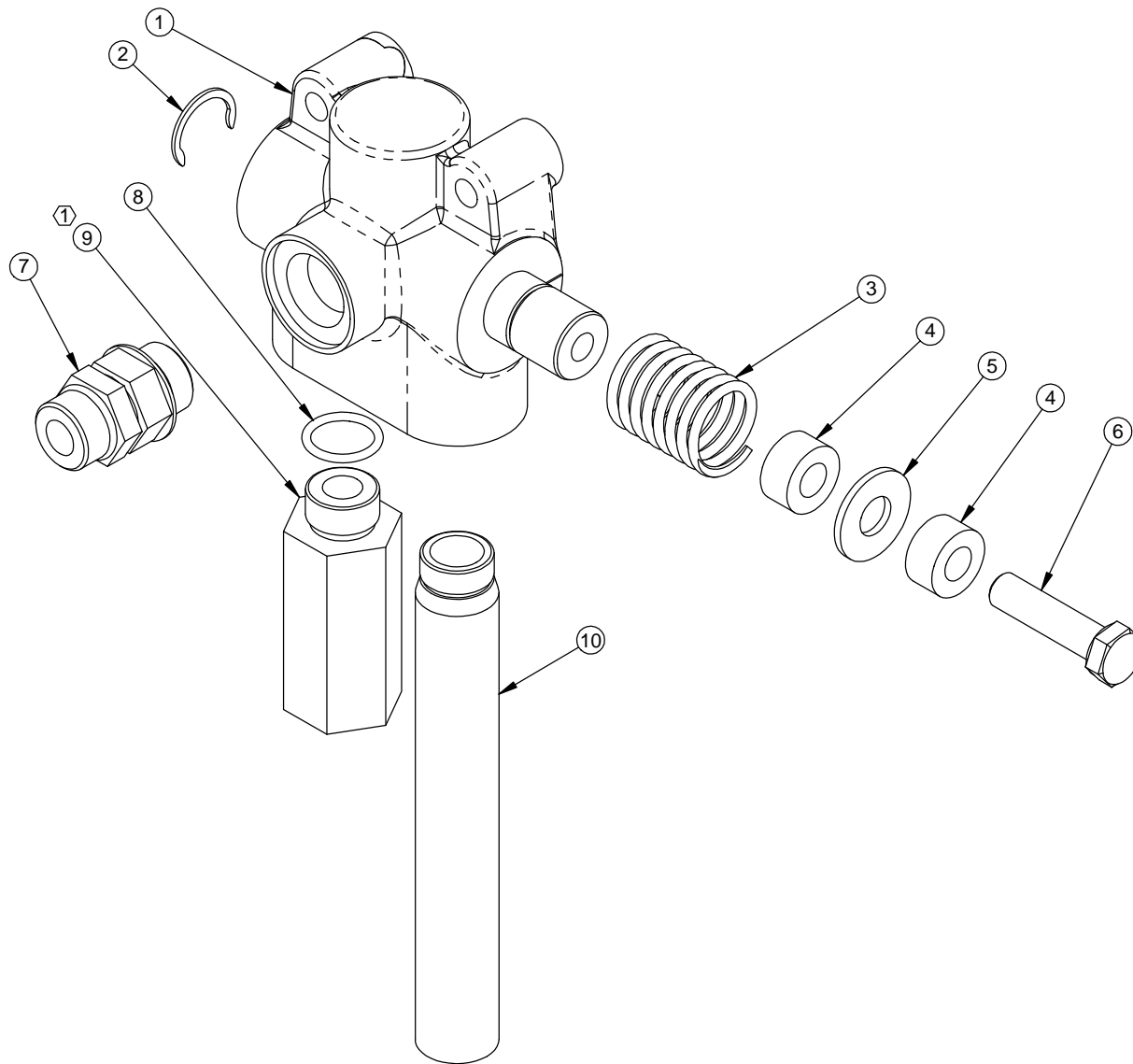

**BARRETO**

TITLE: ACTUATOR VALVE  
 PRODUCT LINE: 1320 & 1620 DATE: 1/4/05  
 SCALE: 1:1.8 DWG# 00277  
 SHEET 1 OF 1

REF.	QTY.	PART NO.	DESCRIPTION
1	1	10804	AXLE, FREE WHEEL HUBS ONLY
2	2	05044	GREASE ZERK, 1/4-28 UNF
3	2	05606	SNAP RING, 1-1/8" EXTERNAL
4	3	03008	THRUST WASHER, 1-1/8 X 1-3/4 X .030
5	2	03013	FELT WASHER, 1-1/8 X 2 X 1/8
6	3	05018	KEY, 1/4 X 1/4 X 1-1/4 HARDENED
7	1	03039	THRUST WASHER, 1-1/8 X 1-3/4 X .060
8	2	05033	HAIR SPRING COTTER P2
9	1	02006-F	SPROCKET, #50 40 TOOTH
10	1	03015-L	#50 ROLLER CHAIN, 63 PITCH WITH MASTER

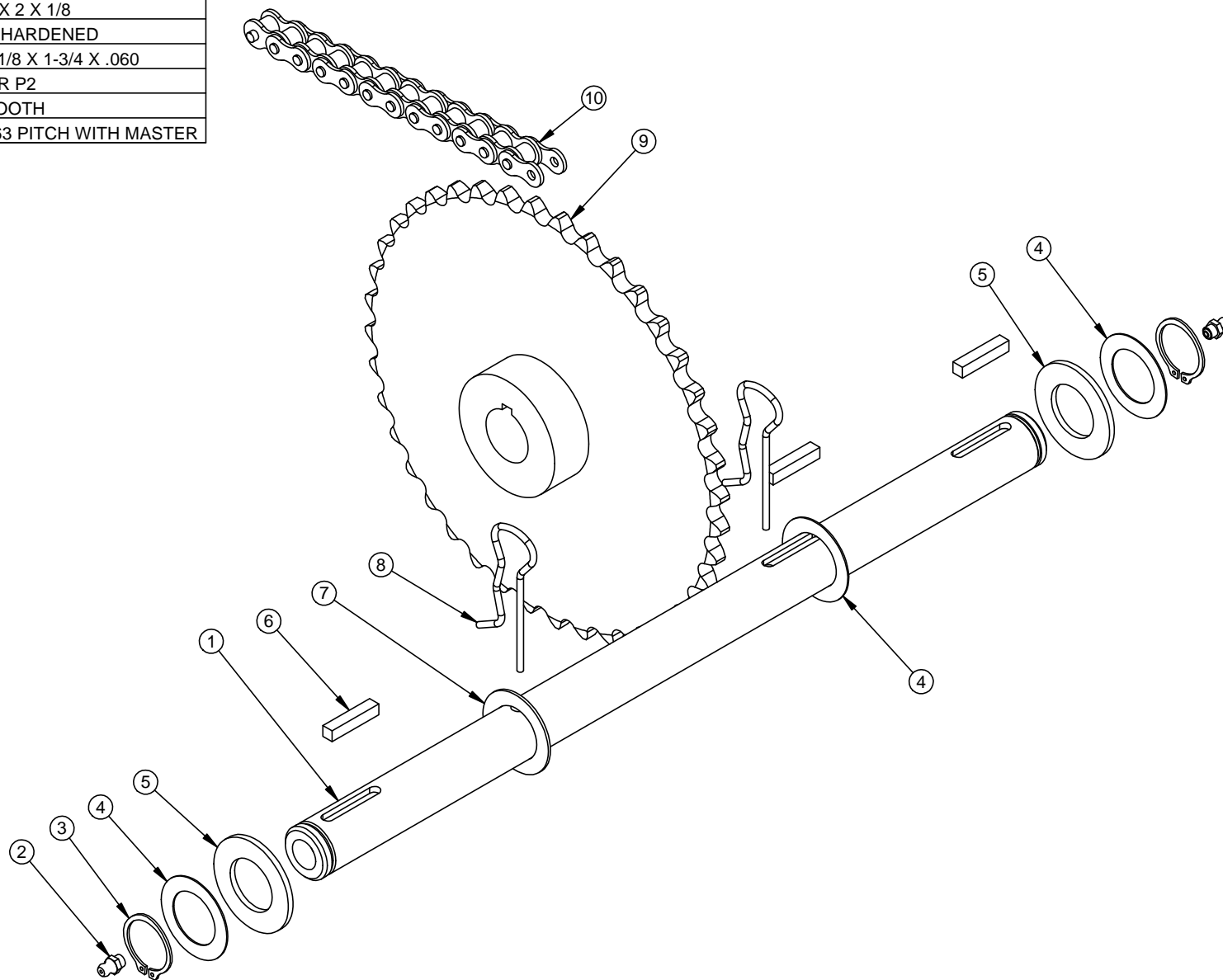

# BARRETO

TITLE: AXLE,  
FOR 1-1/8" FREE WHEEL HUBS  
PRODUCT LINE: 1320 & 1620 7/21/05  
SCALE: 1:3 DWG# 00278 R1  
SHEET 1 OF 1

REF	QTY.	PART NO.	DESCRIPTION
1	1	10532	BODY
2	2	03007	BUSHING, AXLE
3	4	03012	SEAL, AXLE
4	1	10361	FITTING, 6409-8 PLUG
5	1	10536	TORQUE TUBE, 21"
6	4	05046	NUT, GRIPCO, 1/2-13 NC G5 ZINC
7	4	05067	HH CAP SCREW, 1/2-13 NC X 1 G5 ZINC
8	1	03040-10	DECAL, "1320"
9	1	04221	FITTING, 6900-12-12
10	1	03951	FILTER, HYDRAULIC OIL, WITH BY-PASS
11	1	04403	FILTER HEAD, #12 O-RING
12	1	10808	FITTING, 6400-8-12
13	2	03060	BUSHING, IGUS MFI-1012-06
14	1	03020	SEAL
15	1	03061	FELT WASHER, 5/8 X 1 X 1/8
16	1	05096	NUT, NYLOCK, 1/4-20 NC ZINC
17	1	01038	ACTUATOR ARM
18	1	01037	ACTUATOR PLATE
19	1	05125	HH CAP SCREW, 1/4-20 NC X 1-1/4 G5 ZINC
20	1	03040-11	DECAL, "BARRETO", 2-3/16 X 7-3/8
21	1	03041	GASKET, TILLER LID
22	1	03503	SIGHT GAUGE
23	1	03040-57	DECAL, "HYDRAULIC OIL LEVEL"
24	1	01022	LID
25	10	05069	WHIZ LOCK, 1/4-20 NC X 5/8 ZINC
26	1	03520	MAGNET
27	4	05056	HH CAP SCREW, 3/8-24 NF X 1 G5 ZINC
28	10	05101	WASHER, 3/8 SAE ZINC
29	4	05072	NUT, NYLOCK, 3/8-24 NF ZINC
30	1	04517 R1	BREATHER HOSE ASSEMBLY
31	1	03040-06	DECAL, "HYDRAULIC OIL ONLY"
32	1	10526	FITTING, 6409-12 PLUG
33	1	05090	NUT, 1/4-20 NC ZINC
34	1	05237	HH CAP SCREW, 1/4-20 NC X 1 G5 ZINC
35	1	03000	O-RING, 2-234, 3-1/4 OD X 1/8 SECTION
36	1	02004	WHEEL MOTOR SPACER
37	1	03001	O-RING, 2-152, 3-7/16 OD X 3/32 SECTION
38	1	02014	SPROCKET, #50 10 TOOTH
39	2	05021	SET SCREW, 1/4-20 UNC X 5/16, CUP POINT
40	2	04557	FITTING, 6802-8-10
41	1	04003-F	WHEEL DRIVE MOTOR WITH KEY
42	2	05102	WASHER, 1/2 SAE ZINC HARDENED
43	2	05098	NUT, NYLOCK, 1/2-13 NC ZINC
44	4	05092	HH CAP SCREW, 3/8-16 NC X 1-1/2 G5 ZINC
45	1	07005	ENGINE, 13 HP HONDA GX390
46	1	01033-B	ENGINE GUARD, 1320
47	1	06422	IGNITION WIRE, 78"
48	5	03035	TIE WRAP, 1/8 X 6
49	1	03806	QUICK-SPLICE

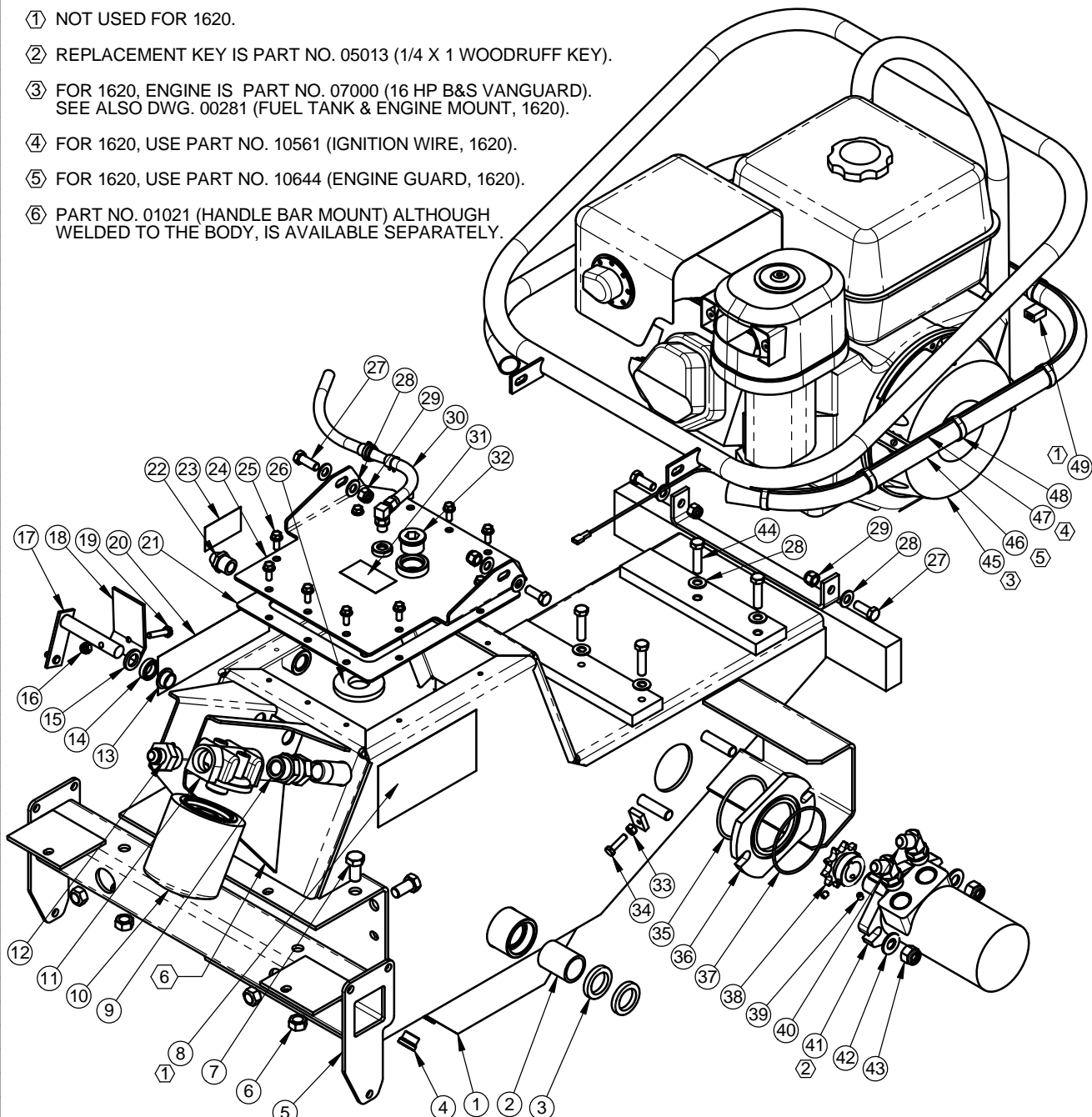

- ① NOT USED FOR 1620.
- ② REPLACEMENT KEY IS PART NO. 05013 (1/4 X 1 WOODRUFF KEY).
- ③ FOR 1620, ENGINE IS PART NO. 07000 (16 HP B&S VANGUARD). SEE ALSO DWG. 00281 (FUEL TANK & ENGINE MOUNT, 1620).
- ④ FOR 1620, USE PART NO. 10561 (IGNITION WIRE, 1620).
- ⑤ FOR 1620, USE PART NO. 10644 (ENGINE GUARD, 1620).
- ⑥ PART NO. 01021 (HANDLE BAR MOUNT) ALTHOUGH WELDED TO THE BODY, IS AVAILABLE SEPARATELY.

TITLE: BODY

PRODUCT LINE: 1320 & 1620      DATE: 1/29/07

SCALE: 1:7.5      SHEET 1 OF 1      DWG# 00279 R5

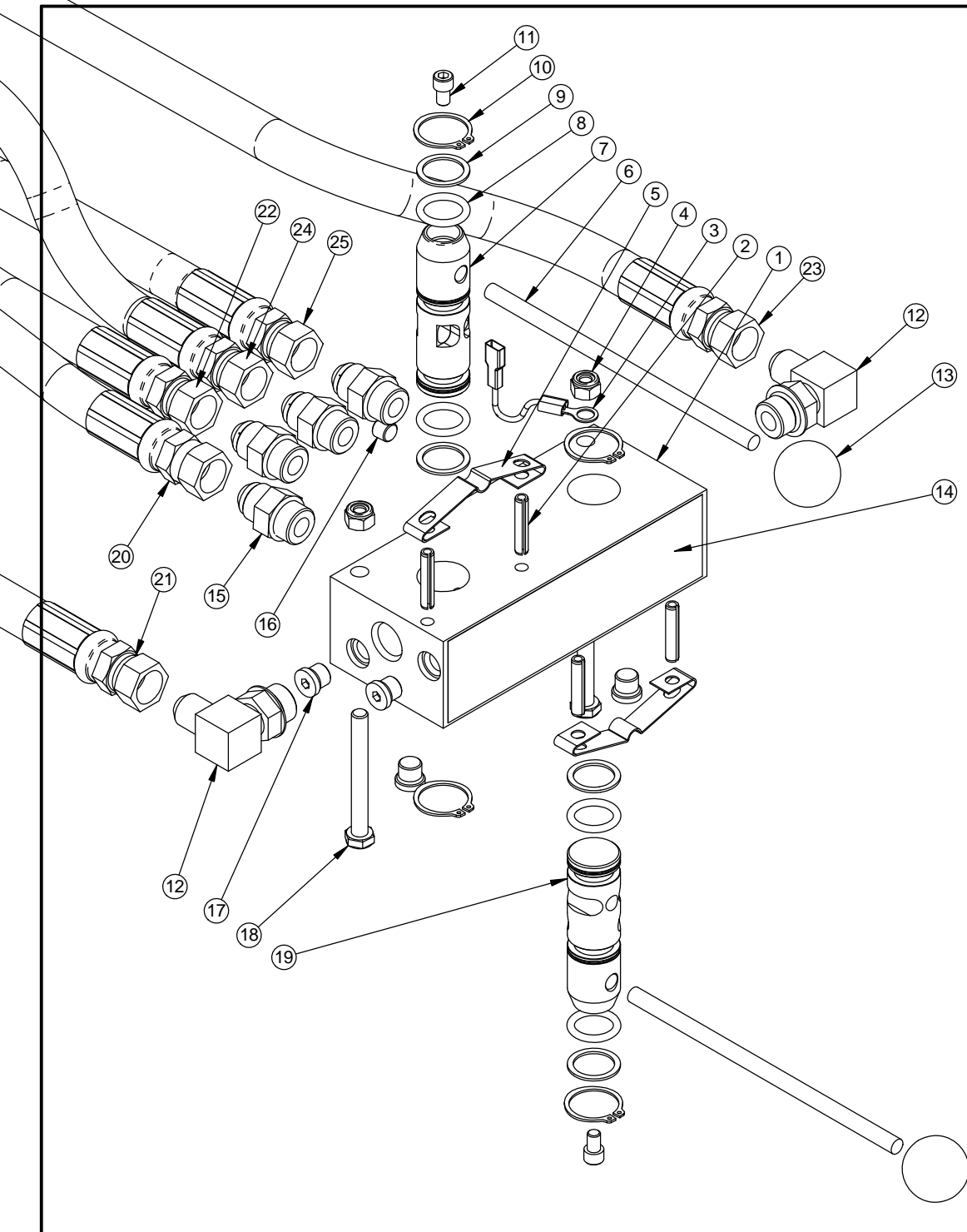

REF	QTY.	PART NO.	DESCRIPTION
1	1	04010	CONTROL VALVE BODY (ORDER 04010-K)
2	4	05200	ROLL PIN (SLOTTED SPRING), 1/4 X 1-1/4 ZINC
3	1	06421	GROUND WIRE, IGNITION SWITCH
4	2	05273	NUT, NYLOCK, 5/16-18 NC ZINC
5	2	03027	DETENT SPRING
6	2	02017	HANDLE, 5/16 X 7
7	1	04015-D	VALVE SPOOL, TINES (ORDER 04010-K)
8	4	03002	O-RING, 2-210, 1" OD X 1/8 SECTION
9	4	03025	BACK-UP RING, 1" TEFLON
10	4	05010	SNAP RING, 1" EXTERNAL
11	2	05573	SH CAP SCREW, 1/4-20 NC X 3/8 ZINC
12	2	04554	FITTING, 6801-8-8
13	2	03026	KNOB, 5/16-NC
14	1	03040	DECAL, CONTROL VALVE
15	4	04520	FITTING, 6400-8-8
16	1	05023	PIPE PLUG, 1/8"
17	4	03300	FITTING, 6409-4 PLUG
18	2	05065	HH CAP SCREW, 5/16-18 NC X 2-3/4 G5 ZINC
19	1	04015-C	VALVE SPOOL, WHEEL DRIVE (ORDER 04010-K)
20	1	04308	HOSE, CONTROL VALVE TO ACTUATOR TEE FITTING
21	1	04309	HOSE, CONTROL VALVE TO TINE MOTOR LOWER PORT
22	1	04310	HOSE, CONTROL VALVE TO TINE MOTOR UPPER PORT
23	1	04311	HOSE, CONTROL VALVE TO WHEEL MOTOR LOWER PORT
24	1	04312	HOSE, CONTROL VALVE TO WHEEL MOTOR UPPER PORT
25	1	04313	HOSE, CONTROL VALVE TO OIL FILTER MOUNT

**BARRETO**

TITLE: CONTROL VALVE  
 PRODUCT LINE: 1320 & 1620 DATE: 4/26/07  
 SCALE: 1:3 SHEET 1 OF 1 DWG# 00280 R2

REF.	QTY.	PART NO.	DESCRIPTION
1	2	05297	HH CAP SCREW, 5/16-18 NC X 1-1/4 G5 ZINC
2	4	10615	WASHER, 5/16 USS ZINC
3	1	10556	MOUNTING BRACKET, FUEL TANK
4	1	10559	FUEL TANK, 1620, INCLUDES KELCH CAP
5	6	05273	NUT, NYLOCK, 5/16-18 NC ZINC
6	1	05131	HH FLANGE SCREW, 5/16-18 NC X 3/4 G8 ZINC
7	1	03062-04	FITTING, 1/8 NPT TO 1/4 HOSE BIB, STRAIGHT
8	4	03062-06	CLAMP, 1/4" FUEL LINE
9	1	11346	HOSE, 1/4" GASOLINE, 4L5, 3 LONG
10	1	03062-03	FUEL SHUT OFF VALVE
11	1	11352	HOSE, 1/4" GASOLINE, 4L5, 24 LONG
12	1	03062-12	FUEL TANK CAP, KELCH
13	2	01014	SPACER, ENGINE
14	4	05068	WASHER, 5/16 SAE ZINC
15	4	05101	WASHER, 3/8 SAE ZINC
16	4	05057	HH CAP SCREW, 3/8-16 NC X 3/4 G5 ZINC
17	1	01013	MOUNTING PLATE, 16 HP B&S ENGINE
18	1	07000-01	MUFFLER, B&S 16HP VANGUARD
19	1	07000-02	CLAMP, MUFFLER, WITH CARRIAGE BOLT & NUT
20	1	07000-03	MOUNTING BRACKET, MUFFLER
21	1	07000-04	MANIFOLD WITH GASKETS & FASTENERS
22	2	03070	SCREW, 6MM
23	2	03071	SCREW, 8MM
24	2	05041	HOSE CLAMP, 1" SS
25	1	01040	HEAT SHIELD, 16 HP B&S ENGINE

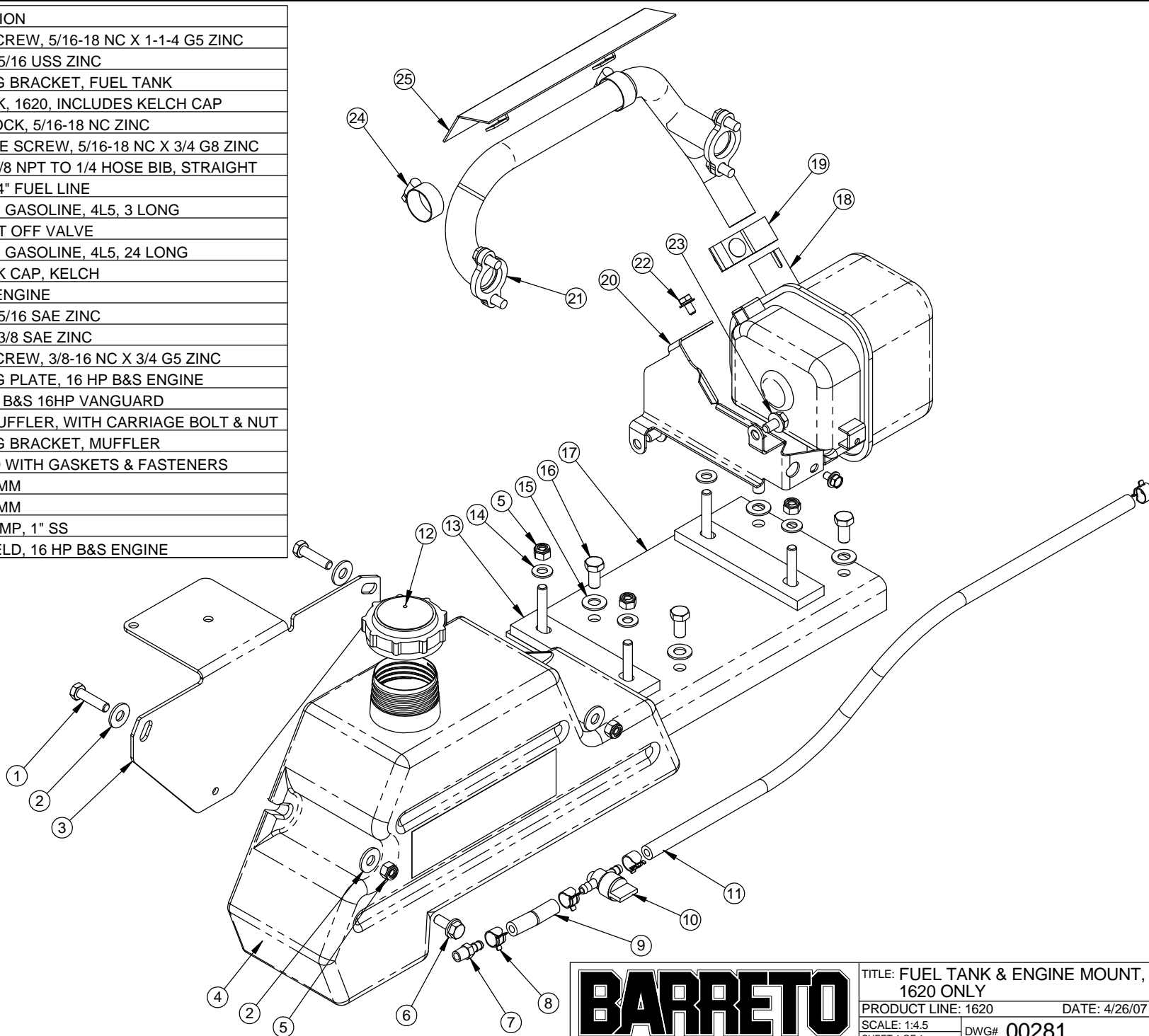

**BARRETO**

TITLE: FUEL TANK & ENGINE MOUNT,  
1620 ONLY  
PRODUCT LINE: 1620 DATE: 4/26/07  
SCALE: 1:4.5 DWG# 00281  
SHEET 1 OF 1



REF.	QTY.	PART NO.	DESCRIPTION	REF.	QTY.	PART NO.	DESCRIPTION
1	1	01017	HANDLE BARS	14	1	03029	LEVER ASSEMBLY (COMPLETE)
2	1	02027-L	HANDLE BAR ADJUSTER PIN, LOWER	15	1	03045	CABLE, ACTUATOR
3	4	05216	SNAP RING, 3/4 EXTERNAL	16	1	05081	WASHER, 1/4 SAE ZINC
4	2	03501	BUSHING, IGUS MFI-0810-08	17	1	05039	CIRCLE COTTER CC-3
5	2	05102	WASHER, 1/2 SAE ZINC HARDENED	18	1	03009	HOUR METER - COMPLETE KIT
6	1	05093	HH CAP SCREW, 1/2-13 NC X 3 G5 ZINC	19	1	03341-07	DECAL, "IGNITION OFF/ON"
7	1	05098	NUT, NYLOCK, 1/2-13 NC	20	1	06420	ROCKER SWITCH, IGNITION OFF/ON
8	1	01030	CRANK, HANDLE BAR ADJUSTMENT	21	2	10667	HOSE KEEPER
9	2	05058	WASHER, 3/8 NYLON	22	2	10668	SPACER, HOSE KEEPER
10	3	05103	WASHER, 3/8 A325 HARDENED ZINC	23	2	05065	HH CAP SCREW, 5/16-18 NC X 2-3/4 G5 ZINC
11	1	02027-U	PIN, HANDLE BAR ADJUSTMENT, UPPER	24	4	05068	WASHER, 5/16 SAE ZINC
12	2	05269	NUT, 3/8-16 NC GRB ZINC	25	2	05273	NUT, NYLOCK, 5/16-18 NC
13	2	03032-01	GRIP, 1 X 5 (P/N 03032 IS A PAIR)				

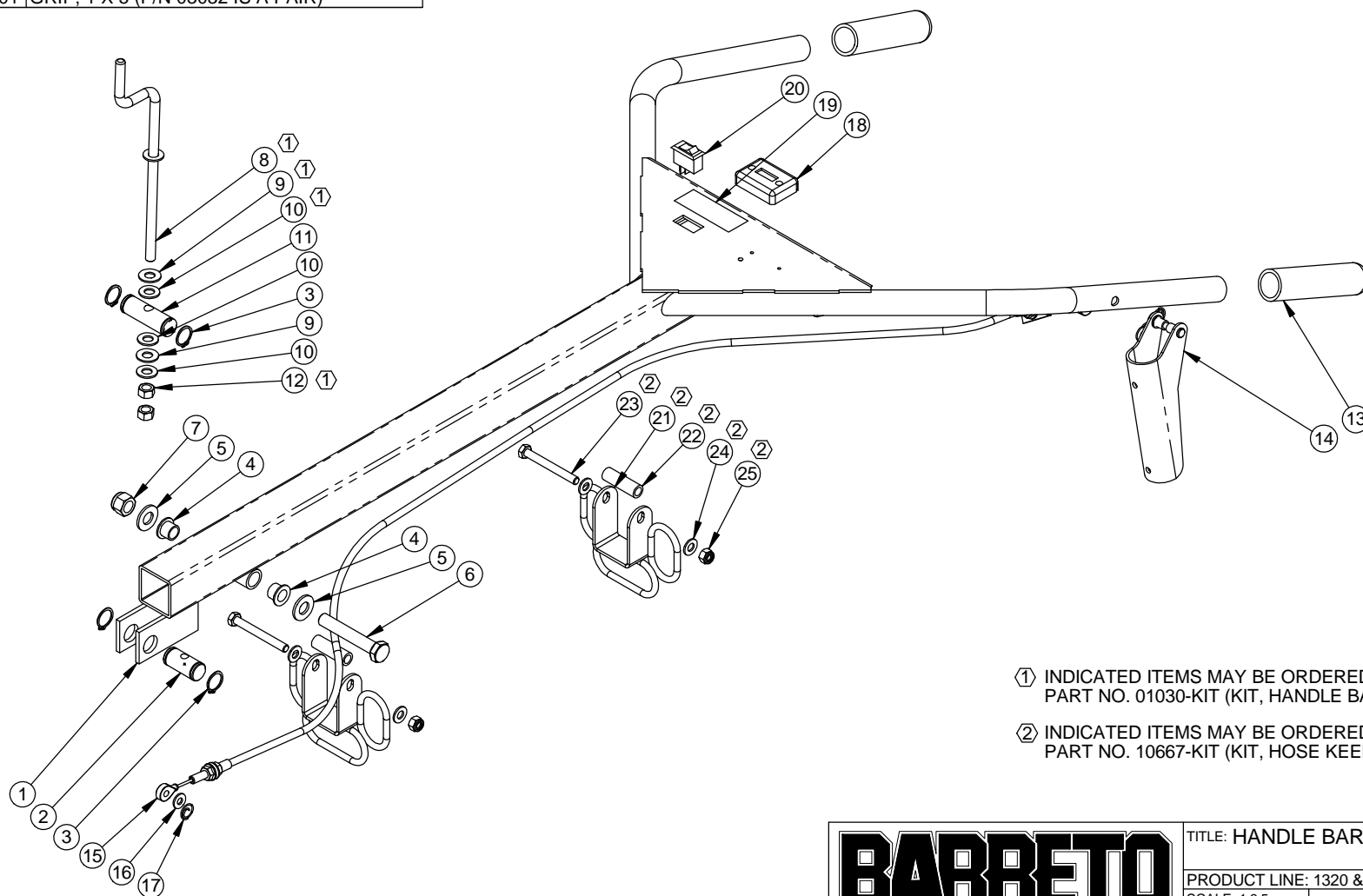

- ① INDICATED ITEMS MAY BE ORDERED AS A KIT, PART NO. 01030-KIT (KIT, HANDLE BAR ADJUSTMENT).
- ② INDICATED ITEMS MAY BE ORDERED AS A KIT, PART NO. 10667-KIT (KIT, HOSE KEEPER W/FASTENERS).

**BARRETO**

TITLE: HANDLE BARS & CRANK

PRODUCT LINE: 1320 & 1620 1/16/07

SCALE: 1:6.5  
SHEET 1 OF 1

DWG# 00282 R1

NOTES:

- ① COMES WITH SET SCREW. REPLACEMENT SET SCREW IS PART NO. 05020 (1/4 X 1/4 NC).
- ② COMES WITH SET SCREW. REPLACEMENT SET SCREW IS PART NO. 05127 (5/16 X 5/16 NC).
- ③ FOR 1620, USE PART NO. 05014 (1/4 X 1/4 X 3/4 KEY).
- ④ FOR 1620, USE PART NO. 04301 (HOSE, INTAKE, 1620).
- ⑤ FOR 1620, USE PART NO. 04305 (HOSE, PUMP TO TEE, 1620).
- ⑥ FOR 1620, QUANTITY OF 04304 IS ONE.

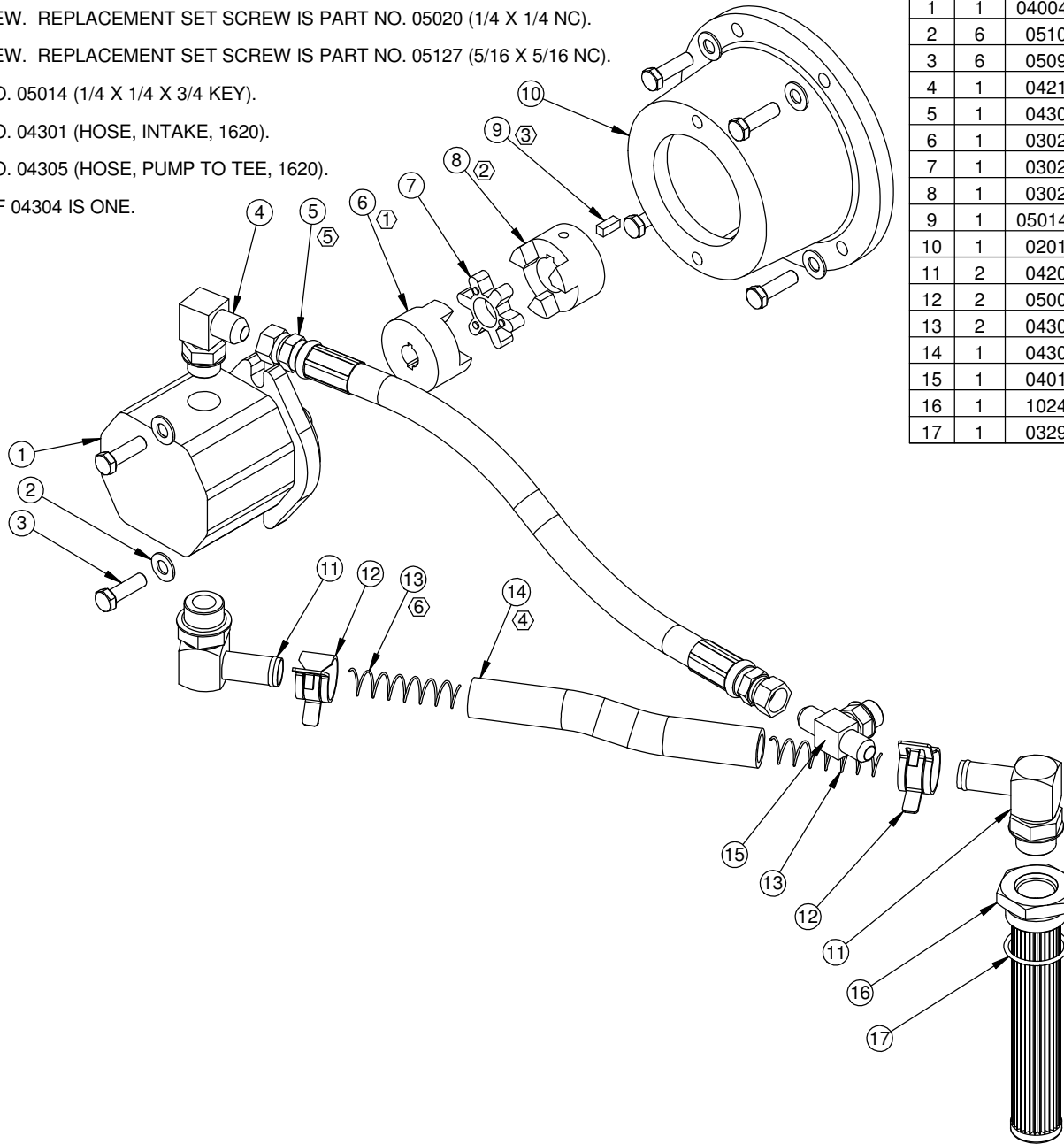

REF.	QTY.	PART NO.	DESCRIPTION
1	1	04004-A	PUMP, HYDRAULIC
2	6	05101	WASHER, 3/8 SAE ZINC
3	6	05091	HH CAP SCREW, 3/8-16 NC X 1-1/4 G5 ZINC
4	1	04211	FITTING, 6801-8-10
5	1	04306	HOSE, PUMP TO TEE, 1320
6	1	03021	JAW COUPLER, PUMP, 5/8" BORE
7	1	03022	SPIDER, RUBBER
8	1	03023	JAW COUPLER, 1" BORE L095
9	1	05014-A	KEY, 1/4 X 1/4 X 5/8
10	1	02016	PUMP ADAPTER
11	2	04202	FITTING, 4601-12-12
12	2	05008	CLAMP, 1" HOSE, CTB-29
13	2	04304	SPRING, 3/4" INTAKE HOSE
14	1	04302	HOSE, INTAKE, 1320
15	1	04017	FITTING, 6803-8-8-8
16	1	10247	SUMP SCREEN #20 EXT #12 INT O-RING
17	1	03293	O-RING, 3-920N90, -20 FITTINGS

**BARRETO**

TITLE: PUMP  
 PRODUCT LINE: 1320 & 1620 DATE: 9/5/07  
 SCALE: 1:4.5 SHEET 1 OF 1  
 DWG# 00283 R1



REF.	QTY.	PART NO.	DESCRIPTION
1	1	10539	LH SIDE PLATE, TINE SECTION
2	12	05056	HH CAP SCREW, 3/8-24 NF X 1 G5 ZINC
3	14	05072	NUT, NYLOCK, 3/8-24 NF
4	4	05300-01	HH CAP SCREW, 1/2-13 NC X 1-1/2 G5 ZINC
5	1	01009	TINE MOTOR MOUNTING BRACKET
6	1	04000T-F	TINE MOTOR, 6.2 CU IN WITH KEY & NUT
7	4	05098	NUT, NYLOCK, 1/2-13 NC
8	1	04209	FITTING, 6410-10-8
9	1	04210	FITTING, 6802-8-8
10	1	04211	FITTING, 6801-8-10
11	1	01024	TINE MOTOR GUARD
12	2	05292	HH CAP SCREW, 3/8-24 NF X 1-1/4 G5 ZINC
13	8	05063	HH CAP SCREW, 7/16-20 NF X 1-1/4 G8 ZINC
14	1	01010-SGT	TINE MOTOR HUB, TAPERED BORE
15	1	01011	TINE SHAFT
16	6	03006-L	LH TINE, HARDFACED
17	6	03006-R	RH TINE, HARDFACED
18	24	05074	NUT, 7/16-20 NF G8 ZINC
19	16	05061	HH CAP SCREW, 7/16-20 NF X 1 G8 ZINC
20	1	10144	OUTBOARD BEARING ASSEMBLY
21	2	05103	WASHER, 3/8 A325 HARDENED ZINC
22	1	05083	WASHER, 7/16 USS ZINC
23	1	05059	HH CAP SCREW, 3/8-16 NC X 1 G5 ZINC
24	1	10538	RH SIDE PLATE, TINE SECTION
25	1	05044	GREASE ZERK, 1/4-28 UNF
26	1	01008	TINE COVER, 1320/1620
27	12	05140	WHIZ LOCK, 5/16 x 3/4
28	12	05273	NUT, NYLOCK, 5/16-18 NC
29	1	01012	DEPTH BAR
30	1	05006	ROLL PIN (SLOTTED SPRING), 3/8 X 1-1/2 ZINC
31	2	05092	HH CAP SCREW, 3/8-16 NC X 1-1/2 G5 ZINC
32	1	01099	HANDLE, DEPTH BAR
33	2	05073	NUT, NYLOCK, 3/8-16 NC
34	1	03018	GRIP
35	1	03080	SPRING
36	1	01018	PIN, DEPTH BAR
37	1	03065	HAIR SPRING COTTER #4
38	1	03040-01	DECAL, "MADE IN USA"
39	1	03040-02	DECAL, "BARRETO", 3-1/2 X 11-1/4
40	1	03040-03	DECAL, "CAUTION" (BLACK & WHITE)
41	1	03040-04	DECAL, "GREASE DAILY"
42	1	03040-07	DECAL, "CAUTION" (YELLOW)
43	1	03040-08	DECAL, "WARNING" (YELLOW)
44	1	03040-11	DECAL, "BARRETO", 2-3/16 X 7-3/8
45	1	03341-22	DECAL, "TILLER OPERATING INSTRUCTIONS"
46	1	03341-23	DECAL, "TILLER SAFETY INSTRUCTIONS"

① PART NO. 05063-24 IS A SET OF 24 CAP SCREWS.

② PART NO. 03006-HF IS A COMPLETE SET OF 6 LH TINES AND 6 RH TINES.

③ PART NO. 05074-24 IS A SET OF 24 NUTS.

④ REFERENCE DWG. 10144 FOR INDIVIDUAL PARTS.

⑤ FOR 1620, SUBSTITUTE PART NO. 03040-09 (DECAL, "1620")

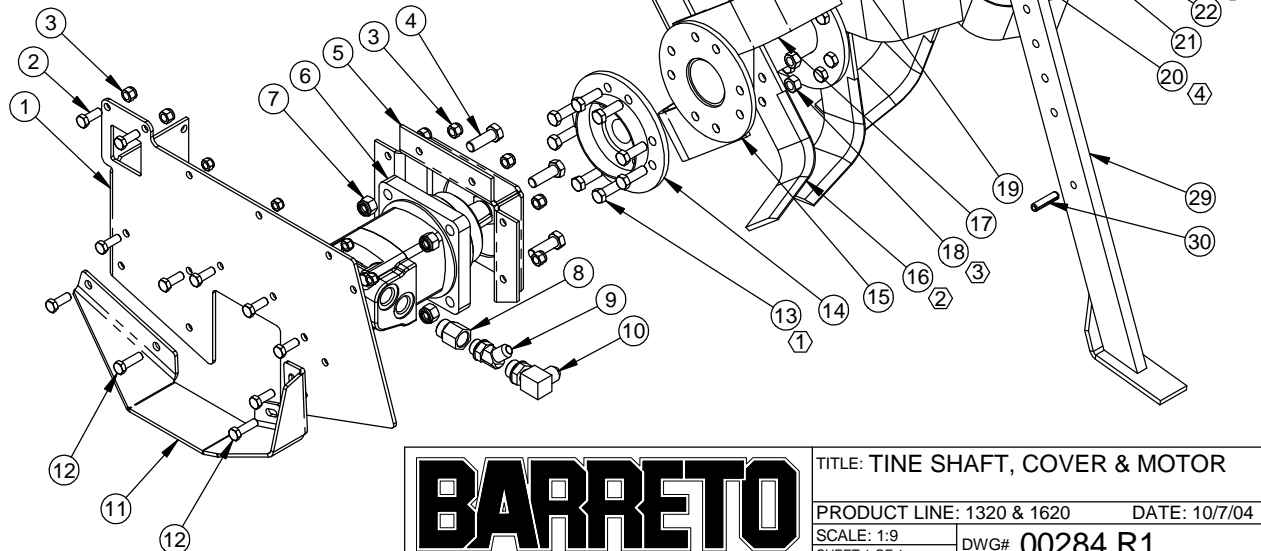

# BARRETO

TITLE: TINE SHAFT, COVER & MOTOR

PRODUCT LINE: 1320 & 1620 DATE: 10/7/04

SCALE: 1:9

DWG# 00284 R1

SHEET 1 OF 1

REF.	QTY.	PART NO.	DESCRIPTION
1	1	04555	FITTING, 6801-4-4
2	1	04214	FITTING, JS-4-4, HOSE BARB 1/4 X 1/4 SWIVEL
3	1	11350	HOSE, 1/4 INCH GASOLINE, 4L5, 5" LONG
4	2	03062-06	CLAMP, 1/4" FUEL LINE
5	1	04516	BREATHER, FILTER SNAPPER 1435
6	1	11351	HOSE, 1/4 INCH GASOLINE, 4L5, 8" LONG

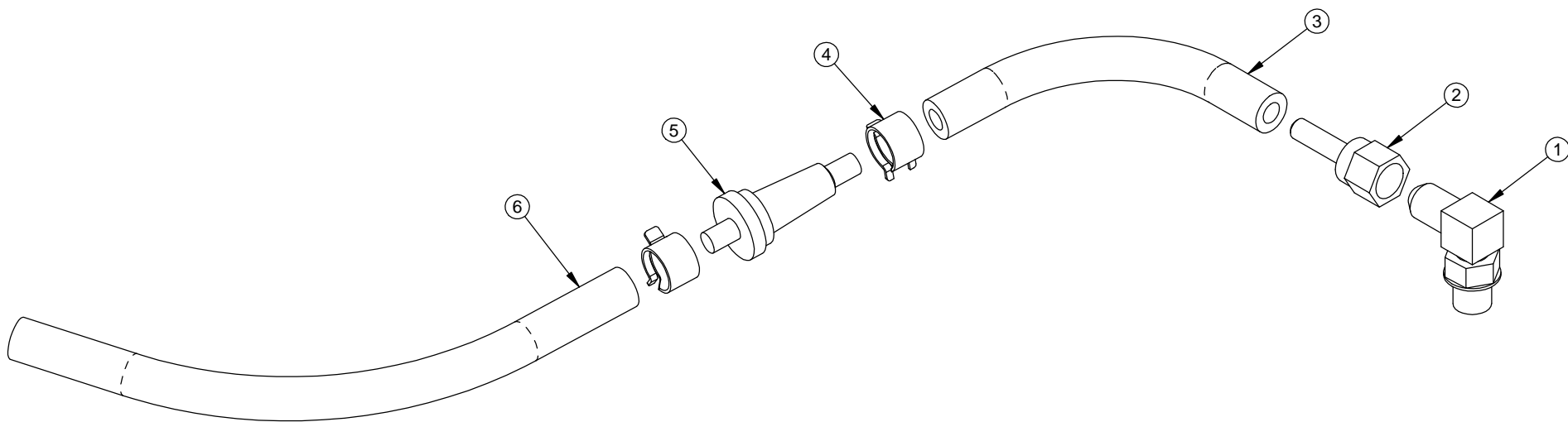

NOTES:

- 1. USAGE: 1 PER 1320 & 1620



TITLE: BREATHER HOSE ASSEMBLY	
PRODUCT LINE: 1320 & 1620	DATE: 4/26/07
SCALE: 1:1.8	DWG# 04517 R1
SHEET 1 OF 1	

REF.	QTY.	PART NO.	DESCRIPTION
1	2	02269-HUB	WHEEL HUB ASSY, 1-1/8" BORE
2	1	03047	TIRE & RIM, TILLER RH, TRENCHER LH, 16 X 6.50 -8
3	1	03046	TIRE & RIM, TILLER LH, TRENCHER RH, 16 X 6.50 -8
4	2	05042	NUT, LUG, 1/2-20 NF
5	2	02068	PIN, FREE WHEELING
6	2	05102	WASHER, 1/2 SAE ZINC HARDENED
7	4	05548	ROLL PIN (SLOTTED SPRING), 1/8 X 3/4 ZINC
8	2	03352	SPRING, CENTURY 3385
9	4	02083	SPACER, WHEEL
10	2	01077	MOUNTING PLATE, PIN, FREE WHEELING
11	4	05076	NUT, GRIPCO, 1/2-20 NF G5 ZINC
12	2	03550	SPLIT RING-27

① REFERENCE DWG# 02269-HUB FOR INDIVIDUAL PARTS.

② RIM ALONE IS PART NO. 03049, TIRE ALONE IS PART NO. 03048.  
CALL REGARDING OPTIONAL FOAM FILLED TIRES.

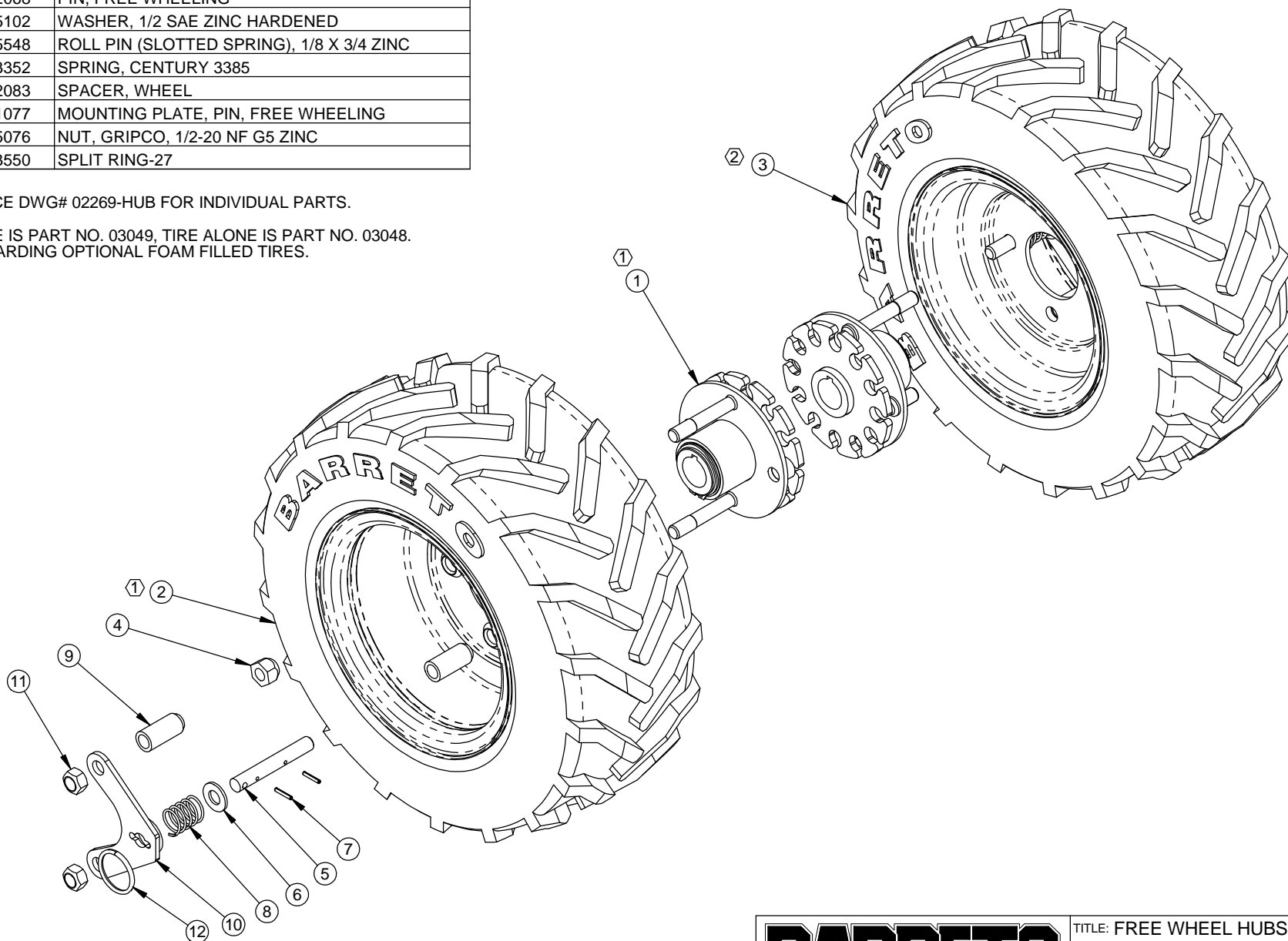

**BARRETO**

TITLE: FREE WHEEL HUBS & WHEELS

PRODUCT LINE: 1320 & 1620 DATE: 8/9/07

SCALE: 1:5  
SHEET 1 OF 1

DWG# 10388